

1' enfance rouge

- hospitality rider
- technical rider

contact :

Elodie Birker : elodie@lastationservice.com
++33 (0)6 280 546 82
++33 (0)9 529 582 74
www.lastationservice.com

contact band :

info@enfancerouge.org

sound engineer :

Alessandro Maffei
alessandro.maffei@inventati.org / +39 3381559569

infos & mp3 :

www.virb.com/enfancerouge www.enfancerouge.org
No MurdochSpace

l' enfance rouge

hospitality rider

4 people :

- 3 musicians from L'Enfance Rouge: François R. Cambuzat, Chiara Locardi, Jacopo Andreini;
- 1 sound engineer: Alessandro Maffei (or Bertrand Perrot).

Catering :

4 people, but 1 is intolerant to gluten.

At arrival/get in:

Fresh fruits; 3 tablets of dark chocolate (no Nestlé and affiliated); nut mix; chips; salad/carrots; ham; cheese; bread; fruit juices; 5 liters of spa mineral water; green thee; coffee; 1 bottle of wine; 10 beers; free drink tickets...

A warm diner + salad for 4 people: restaurant, cantine, friendly kitchen or other. (NB: 1 intolerance to gluten.) Drinks.

On stage: 4 mineral water, 4 towels.

Hotel :

A 2 stars minimum with continental breakfast for 4 people. Rooms: 1 double, 2 single.

The keys and codes (for night & day entrance) will be provided by the promoter/organizer and given to the band before the concert.

IMPORTANT: We absolutely need a WATCHED, closed and safe parking place for a van higher than 2,50 meters.

contact :

Elodie Birker : elodie@lastationservice.com
++33 (0)6 280 546 82
++33 (0)9 529 582 74
www.lastationservice.com

contact band :

info@enfancerouge.org

sound engineer :

Alessandro Maffei
alessandro.maffei@inventati.org / +39 3381559569

infos & mp3 :

www.virb.com/enfancerouge www.enfancerouge.org
No MurdochSpace

l' enfance rouge

hospitality rider (français)

4 personnes :

- 3 musiciens de L'Enfance Rouge: François R. Cambuzat, Chiara Locardi, Jacopo Andreini;
- 1 ingénieur du son: Alessandro Maffei ou Bertrand Perrot.

Catering :

- 4 personnes, dont une intolérante au gluten.

A l'arrivée / get in :

- Fruits frais; 3 tablettes de chocolat noir (pas de Nestlé et affiliés), mélange de fruits secs (+ noix, noisettes, ...); chips; salade/carottes; charcuterie; fromage; pain; jus de fruits; 5 litres d'eau minérale plate; thé vert; café; 1 bouteille de vin; 10 bières; free drink tickets...

- Repas chaud (dîner) + salade pour 4 personnes: restaurant, cantine, cuisine familiale ou autre (NB: 1 intolérance au gluten). Boissons.

- Pour la scène, prévoir 8 bouteilles d'eau minérale et 4 serviettes.

Hébergement :

Un hôtel deux étoiles minimum avec petits déjeuners complets pour 4 personnes (1 chambre twin, 2 chambres simples), ainsi qu'un **parking fermé** et **surveillé** pour un véhicule d'une hauteur de plus de 2,50 m. Les clés et/ou codes des chambres seront préalablement retirés auprès de l'hôtel par L'ORGANISATEUR qui s'assurera de les remettre aux artistes à leur arrivée sur le lieu du concert ainsi que les clés et/ou les codes d'entrée nocturne de l'hôtel, de même que les clés et/ou les codes de l'accès diurne et nocturne du parking.

contact :

Elodie Birker : elodie@lastationservice.com
++33 (0)6 280 546 82
++33 (0)9 529 582 74
www.lastationservice.com

contact band :

info@enfancerouge.org

sound engineer :

Alessandro Maffei
alessandro.maffei@inventati.org / +39 3381559569

infos & mp3 :

www.virb.com/enfancerouge www.enfancerouge.org
No MurdochSpace

l' enface rouge

technical rider

09 2008

FOH

- good quality multiway electronic processed pa system with s/woofers installed and working, capable of 110 dB/A at FOH console position with full dynamic and frequency range for typical rock music. very wide stage also need an additional front fill system.
- FOH console position should be centered with respect to the stage at a distance from stage slightly greater (1,2x - 1,5x) than the distance between the two groups of speakers (LR);
- professional grade analogue mixing console with 10 mic + 4 line free inputs;
- dual channel graphic equalizer unit (bss, klarktechnik...) connected to the LR output;
- a total of 4 dynamic compressor channels (drawmer, bss, dbx...);
- 2 noise gate channels;
- 1 digital reverb unit (lexicon, yamaha, tc-electronic...)
- CDJ player to be used during the show (POST fader feed to monitors is needed);

MONITOR

- 1 experienced monitor engineer should be provided by the venue/promoter from the set-up until the end of the show;
- 3 musicians on stage, minimum stage size are 5m x 3m;
- 6 professional grade monitor wedges (5 on stage and 1 for engineer, please all wedges must be the same type and in good working order); amplifiers capable of enough power headroom;
- no sidefills are needed;
- the monitor mixing console should be placed on a side of the stage, the monitor engineer should be able to see and interact with musicians during the set up, the soundcheck and the show;
- professional grade monitor mixing console with 10 mic inputs and 5 output buses. In some cases, for very small venues, monitor mix can be done from FOH, but the FOH console need at least 3 aux buses PRE fader in addition to the fx sends;
- 5 channels of good graphic equalization at monitor mix position (bss, klark);
- 1 dual channel dynamic compressor.

sound engineer :

Alessandro Maffei

alessandro.maffei@inventati.org / +39 3381559569

l' enfance rouge

patch list

ch	stand	source	note	ins
01	table	kick	akg d112, ev p1/re20, shure beta52	gate 1
02	short	snare	shure sm57	-
03	clamp	floor tom	sennheiser e604, md421, shure sm98	gate 2
04	short	ride	shure sm81, akg c451	-
05	short	hihat	shure sm81, akg c451	-
06	-	bass DI	active D.I. box	comp 1
07	short	bass MIC	sennheiser md421, shure sm57	comp 2
08	short	guitar	sennheiser md421, shure sm57	-
09	long	voice (chiara)	shure beta58, sm58	comp 3
10	long	voice (françois r.)	shure sm58	comp 4

sound engineer :

Alessandro Maffei

alessandro.maffei@inventati.org / +39 3381559569

1' enfance rouge

stage plan

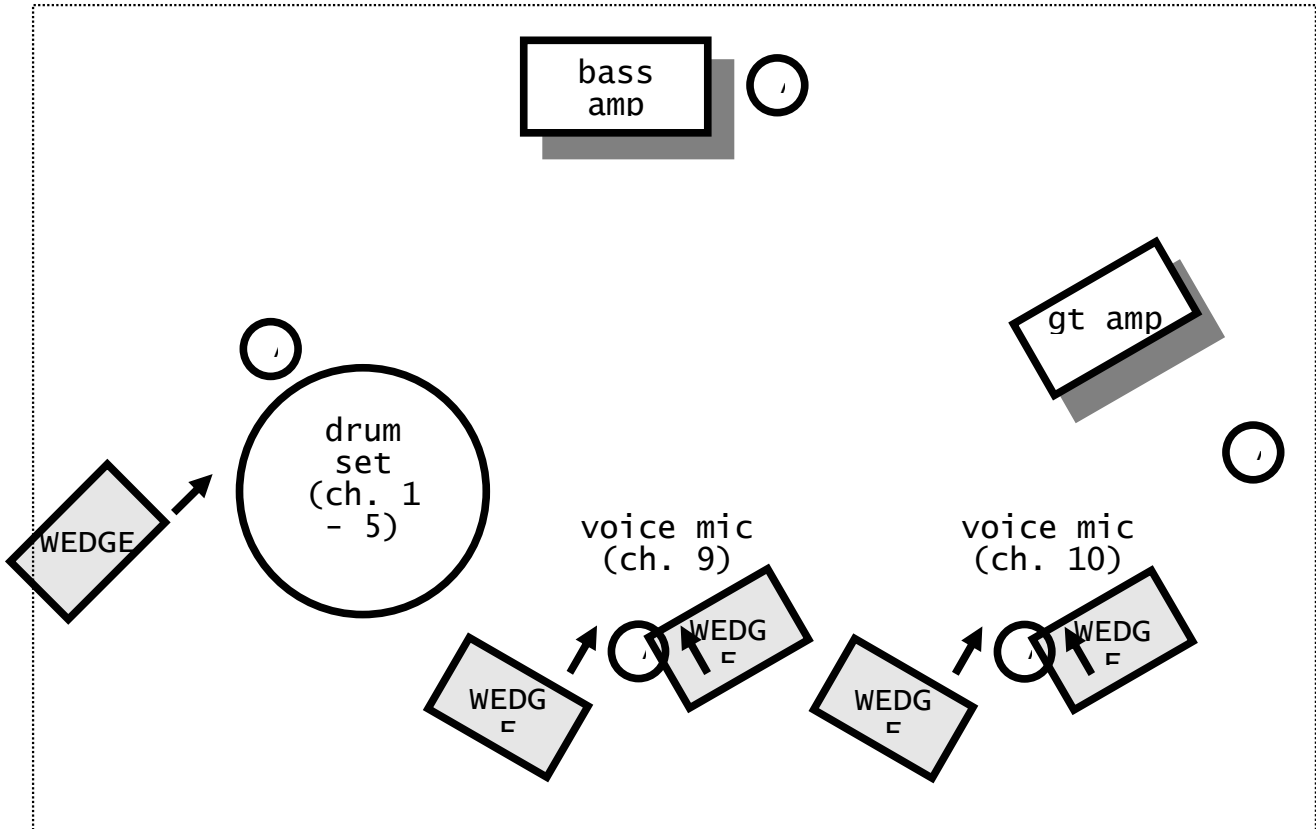

LIGHTS

- all lights should be blue except 6 red footlights on the back of the stage;
- each musician will operate his own foot-switched light during the show;

EXTRAS

- is absolutely a NEED to keep the arrangement shown in the stage plan, the drum set cannot be in the center of the stage nor on a riser;
- a total of 5 clean 230v/50Hz earthed AC outlets are needed on stage, the total power consumption will be less than 3,5kw, see stage plan;
- in a trouble free situation, we need approximately one half hour for setup (mic + backline) and 1 - 1,5 hours for a full soundcheck. this NOT include the time for systems setup and troubleshooting.

contact :

Elodie Birker : elodie@lastationservice.com

++33 (0)6 280 546 82

++33 (0)9 529 582 74

www.lastationservice.com

contact band :

info@enfancerouge.org

sound engineer :

Alessandro Maffei

alessandro.maffei@inventati.org / +39 3381559569

infos & mp3 :

www.virb.com/enfancerouge www.enfancerouge.org

No MurdochSpace